

ARI-ZEDOX® - Fig. 123 - Thread Connection high performance valve - Double offset

ARI-ZEDOX®
with hand lever

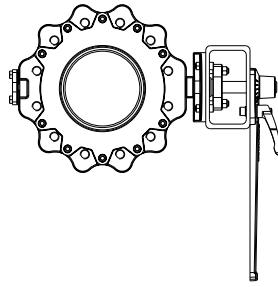

Page 5



Fig. 123 -
ARI-ZEDOX® Thread Connection - short pattern

ARI-ZEDOX®
with worm gear

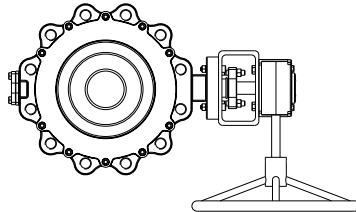

Page 6

ARI-ZEDOX®
with electric rotary actuator
Auma

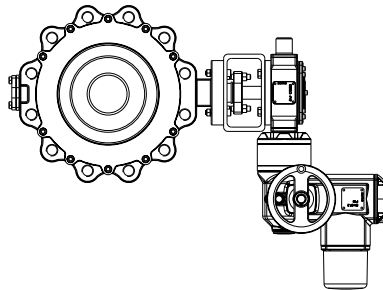

Page 7



DN80-DN250
honeycomb
shape disc

ARI-ZEDOX®
with pneumatic actuator

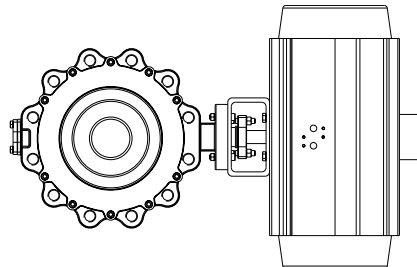

Page 8



DN300-DN800
Disc

ARI-ZEDOX®
with hydraulic actuator

on request



Features:

- Short pattern and middle pattern (K1, K2)
- Cast steel / stainless steel body
- Double offset construction:
Rotary movement (90°) without wear or friction
- Metallic or PTFE+C sealing
- Bi-directional tightness up to differential pressure 25 bar
- Replaceable seat ring
- Firesafe acc. to ISO 10497/ BS6755
- ATEX (optional)

Thread Connection high performance valve (Cast steel, Stainless steel)

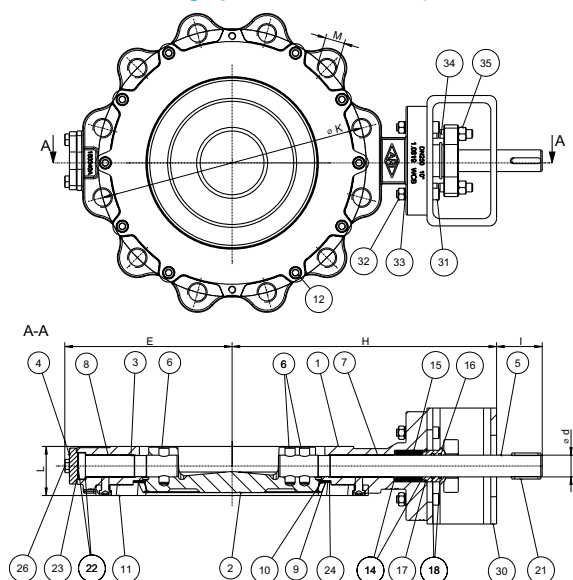

Figure	Nominal pressure	Material	Nominal diameter	Sealing elements
34.123	PN10 - PN25	1.0619+QT	DN 80-600	PTFE+C (TS)
			DN 80-800	Stainless steel (CS)
35.123	PN40	1.0619+QT	DN 80-200	Stainless steel (CS)
54.123	PN10 - PN25	1.4408	DN 80-600	PTFE+C (TS)
			DN 80-800	Stainless steel (CS)
55.123	PN40	1.4408	DN 80-200	Stainless steel (CS)

Face-to-face dimension acc. to ISO 5752 / DIN EN 558-1
 Series 20 DIN3202 K1 (short pattern)
 Series 25 DIN3202 K2 (middle pattern)
 On request: drilled acc. to ANSI150

Sealing element:	
• PTFE+C (TS) ¹⁾	-40°C to 180°C
• Stainless steel (CS)	-40°C to 260°C
¹⁾ Observe operating limits with sealing PTFE+C, refer to page 4	
Max. differential pressure:	
34.123	• 16 bar - standard
54.123	• 25 bar - option
35.123	• 40 bar - standard
55.123	

Actuation arrangement:	
• Hand lever	• Pneumatic actuator
• Worm gear	• Hydraulic actuator
• Electric actuator	
Sealing leakage test:	
PTFE+C	• DIN EN 12266-1 Leckrate A
Stainless steel	• DIN EN 12266-1 Leckrate B

Options on request

Parts				
Pos.	Sp.p.	Description	Fig. 34.123 / 35.123	Fig. 54.123 / 55.123
1		Body	1.0619+QT	1.4408
2		Disc	1.4408 (DN80-DN250); 1.4460 (DN300-DN800)	
3		Pivot	1.4460 (DN80-DN300); 1.4418 (DN350-DN800)	
4		Subshaft cover	1.4404	
5		Stem	1.4460 (DN80-DN300); 1.4418 (DN350-DN800)	
6		Pin	1.4462	
7		Bushing	PTFE on stainless steel net	
8		Bushing	PTFE on stainless steel net	
9 / 24	x	Shim ²⁾	978-C / SIGRAFLEX HOCHDRUCK (SIGRAFLEX HIGH PRESSURE for steam version)	
10	x	Seat ring	CS: 1.4404 (optional: 1.4539) TS: PTFE+C; special material on request	
11		Counter flange	1.0425	1.4404; 1.4408 ³⁾
12		Socket screw	A4-70	
14		Back-up-ring	1.4404	
15	x	Box packing	Graphite	
16		Shaft seal bushing	1.4404	
17 / 18	x	O-ring	EPDM / FPM (Not fitted in steam version)	
19		Gland	1.4301 (DN 80-125); 1.4408 (DN150-800)	
21		Key	1.0503	
22		Axial-washer	PTFE on stainless steel net	
23	x	Bottom cover gasket	978-C / SIGRAFLEX HOCHDRUCK (SIGRAFLEX HIGH PRESSURE for steam version)	
26		Socket screw	A4-70	
30		Mounting bracket	1.0576 (galvanized)	
31		Socket screw	A4-70	
32		Hexagon nut	A4-70	
33		Retaining washers pair	A4	
34		Stud	A4-70	
35		Hexagon nut	A4-70	
L Spare parts				

²⁾ Only for CS-version

³⁾ The material depends on size and face-to-face-dimension

Information / restriction of technical rules need to be observed!

The engineer, designing a system or a plant, is responsible for the selection of the correct valve.

Resistance and suitability must be verified (contact manufacturer for information, refer to Product overview).

TS = PTFE+C (Teflon) seal and Stainless steel disc

CS = Chromed seating and Stainless steel disc

DN	80	100	125	150	200	250	300	350	400	450	500	600	700	800
----	----	-----	-----	-----	-----	-----	-----	-----	-----	-----	-----	-----	-----	-----

Face-to-face dimension acc. to ISO 5752 / DIN EN 558-1															
L Series 20 (short pattern)	(mm)	46	52	56	56	60	68	78	78	102	114	127	154	165	190
L Series 25 (middle pattern)	(mm)	49	56	64	70	71	76	83	92	-	-	-	-	-	-

Dimensions															
Ød	(mm)	15	20	20	25	25	30	35	40	50	50	60	70	70	90
E	(mm)	119	136	155	170	202	231	273	305	333	359	394	460	510	570
H	(mm)	215	240	251	279	320	365	404	431	476	504	574	676	798	846
l	(mm)	45	52	52	58	58	63	69	75	86	86	103	119	119	125
Drive flange ISO 5211		F07	F07	F07	F10	F12	F12	F14	F14	F16	F16	F16	F25	F30	F30

Standard-flange dimensions / Threads (Dimensions, Quantity, Screw depth) per side																	
PN10	Flange hole	ØK	(mm)	160	180	210	240	295	350	400	460	515	565	620	725	840	950
		Total number of threads (M)	(n)	8	8	8	8	8	12	12	16	16	20	20	20	24	24
		Threads	(mm)	M16	M16	M16	M20	M20	M20	M20	M20	M24	M24	M24	M24	M27	M27
	Screw	Number ¹⁾	(n)	8	8	8	8	8	12	12	16	16	16	16	16	20	20
		Thread depth disc side ¹⁾	(mm)	23	26	29	27	27	34,5	34	35	50	59	62,8	79	80	94
		Thread depth shaft side ¹⁾	(mm)	20	23	24	26	30	30	40	40	48	50	60	70	80	90
		Number ²⁾	(n)	-	-	-	-	-	-	-	-	-	4	4	4	4	4
		Thread depth disc side ²⁾	(mm)	-	-	-	-	-	-	-	-	-	24	24	27	27	35
		Thread depth shaft side ²⁾	(mm)	-	-	-	-	-	-	-	-	-	24	24	27	27	35
PN16	Flange hole	ØK	(mm)	160	180	210	240	295	355	410	470	525	585	650	770	840	950
		Total number of threads (M)	(n)	8	8	8	8	12	12	12	16	16	20	20	20	24	24
		Threads	(mm)	M16	M16	M16	M20	M20	M24	M24	M24	M27	M27	M30	M33	M33	M33
	Screw	Number ¹⁾	(n)	8	8	8	8	12	12	12	16	16	16	16	16	20	20
		Thread depth disc side ¹⁾	(mm)	23	26	29	27	27	34,5	34	35	50	59	62,8	79	80	94
		Thread depth shaft side ¹⁾	(mm)	20	23	24	26	30	30	40	40	48	50	60	70	80	90
		Number ²⁾	(n)	-	-	-	-	-	-	-	-	-	4	4	4	4	4
		Thread depth disc side ²⁾	(mm)	-	-	-	-	-	-	-	-	-	27	30	33	33	35
		Thread depth shaft side ²⁾	(mm)	-	-	-	-	-	-	-	-	-	27	30	33	33	35
PN25	Flange hole	ØK	(mm)	160	190	200	250	310	370	430	490	550	600	660	770	875	990
		Total number of threads (M)	(n)	8	8	8	8	12	12	16	16	16	20	20	20	24	24
		Threads	(mm)	M16	M20	M24	M24	M24	M27	M27	M30	M33	M33	M33	M36	M39	M45
	Screw	Number ¹⁾	(n)	8	8	8	8	12	12	16	16	16	16	16	16	20	20
		Thread depth disc side ¹⁾	(mm)	23	26	29	27	27	34,5	34	35	50	59	62,8	79	80	94
		Thread depth shaft side ¹⁾	(mm)	20	23	24	26	30	30	40	40	48	50	60	70	80	90
		Number ²⁾	(n)	-	-	-	-	-	-	-	-	-	4	4	4	4	4
		Thread depth disc side ²⁾	(mm)	-	-	-	-	-	-	-	-	-	33	33	30	40	35
		Thread depth shaft side ²⁾	(mm)	-	-	-	-	-	-	-	-	-	33	33	30	40	35
PN40	Flange hole	ØK	(mm)	160	190	220	250	320	-	-	-	-	-	-	-	-	
		Total number of threads (M)	(n)	8	8	8	8	12	-	-	-	-	-	-	-	-	
		Threads	(mm)	M16	M20	M24	M24	M27	-	-	-	-	-	-	-	-	
	Screw	Number ¹⁾	(n)	8	8	8	8	12	-	-	-	-	-	-	-	-	
		Thread depth disc side ¹⁾	(mm)	23	26	29	27	27	-	-	-	-	-	-	-	-	
		Thread depth shaft side ¹⁾	(mm)	20	23	24	26	30	-	-	-	-	-	-	-	-	
		Number ²⁾	(n)	-	-	-	-	-	-	-	-	-	-	-	-	-	
		Thread depth disc side ²⁾	(mm)	-	-	-	-	-	-	-	-	-	-	-	-	-	
		Thread depth shaft side ²⁾	(mm)	-	-	-	-	-	-	-	-	-	-	-	-	-	

¹⁾ Tapped through hole (see picture below) ²⁾ Tapped blind hole (see picture below)

Caution: Thread sizes ≥ M30 are not tapped all the way through

Thread pitch acc. to DIN 13-1

Thread depth is measured from flange face

Compliant with DIN EN 593 by ensuring effective thread depth of 1xD or 0,67xD

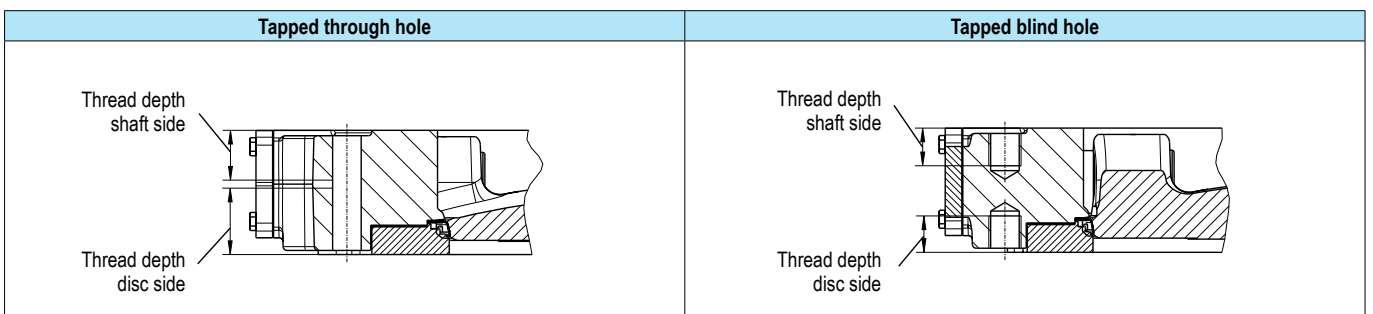

DN	80	100	125	150	200	250	300	350	400	450	500	600	700	800
----	----	-----	-----	-----	-----	-----	-----	-----	-----	-----	-----	-----	-----	-----

Weights for thread Connection high performance valve																	
1.0619+QT	Fig. 34./35.123	short pattern	(kg)	13	16	20	30	41	56	87	111	159	210	270	444	584	888
		middle pattern		on request								-	-	-	-	-	-
1.4408	Fig. 54./55.123	short pattern	(kg)	on request								-	-	-	-	-	-
		middle pattern		on request								-	-	-	-	-	-

Pressure-temperature-ratings Intermediate values for max. permissible operational pressure can be determined by linear interpolation of the given temperature / pressure chart.

acc. to Högfors standard	PN		-40 °C	0 °C	50 °C	100 °C	150 °C	200 °C	250 °C	260 °C
1.0619+QT	10	(bar)	10	10	10	9,2	8,8	8,3	7,6	7,4
1.0619+QT	16	(bar)	16	16	16	14,8	14	13,3	12,1	11,9
1.0619+QT	25	(bar)	25	25	25	23,4	22,2	21	19,2	18,8
1.0619+QT	40	(bar)	40	40	40	37,4	35,5	33,6	30,7	30,1

acc. to Högfors standard	PN		-40 °C	0 °C	50 °C	100 °C	150 °C	200 °C	250 °C	260 °C
1.4408	10	(bar)	10	10	10	9,4	8,6	7,9	7,4	7,3
1.4408	16	(bar)	16	16	16	15,1	13,7	12,7	11,9	11,7
1.4408	25	(bar)	25	25	25	23,8	21,4	18,9	17,5	17,2
1.4408	40	(bar)	40	40	40	38,1	34,2	30,2	28,0	27,6

Operating limits sealing element ¹⁾ Intermediate values for max. differential pressure can be determined by linear interpolation of the given temperature / pressure chart.

Sealing PTFE+C (TS)	-40 °C	0 °C	50 °C	100 °C	120 °C	150 °C	180 °C	200 °C	250 °C	260 °C
	25	25	25	25	25	14,5	4	-	-	-

¹⁾ Note additional restrictions of the pressure-temperature-ratings!

DN	80	100	125	150	200	250	300	350	400	450	500	600	700	800
----	----	-----	-----	-----	-----	-----	-----	-----	-----	-----	-----	-----	-----	-----

Max. differential pressure																
Sealing PTFE+C (TS)	Disc Side	(bar)	25	25	25	25	25	25	16	16	16	16	16	16	-	-
	Shaft Side	(bar)	25	25	25	25	25	25	25	25	16	16	16	16	16	-
	Bi-directional	(bar)	-	-	-	-	-	-	-	-	-	-	-	-	-	-
Sealing stainless steel (CS)	Disc Side	(bar)	40	40	40	40	40	25	25	25	16	16	16	16	16	16
	Shaft Side	(bar)	25	25	25	25	25	25	16	16	16	16	16	16	16	16
	Bi-directional	(bar)	25	25	25	25	25	25	16	16	16	16	16	16	16	16

Operation torque for max. differential pressure 16 bar (bi-directional flow)

PN ²⁾	Sealing PTFE+C	Torque ³⁾	(Nm)	70	100	140	190	320	550	850	1300	1800	2400	3400	5500	-	-
PN25 ²⁾	Sealing stainless steel		(Nm)	90	130	180	240	400	700	1100	1600	2200	3000	4200	6800	10000	13000
	Sealing stainless steel		(Nm)	135	180	250	285	505	-	-	-	-	-	-	-	-	-

²⁾ max. differential pressure 16bar!

³⁾ For steam duty use the next size up

ZEDOX® Thread Connection high performance valve with hand lever

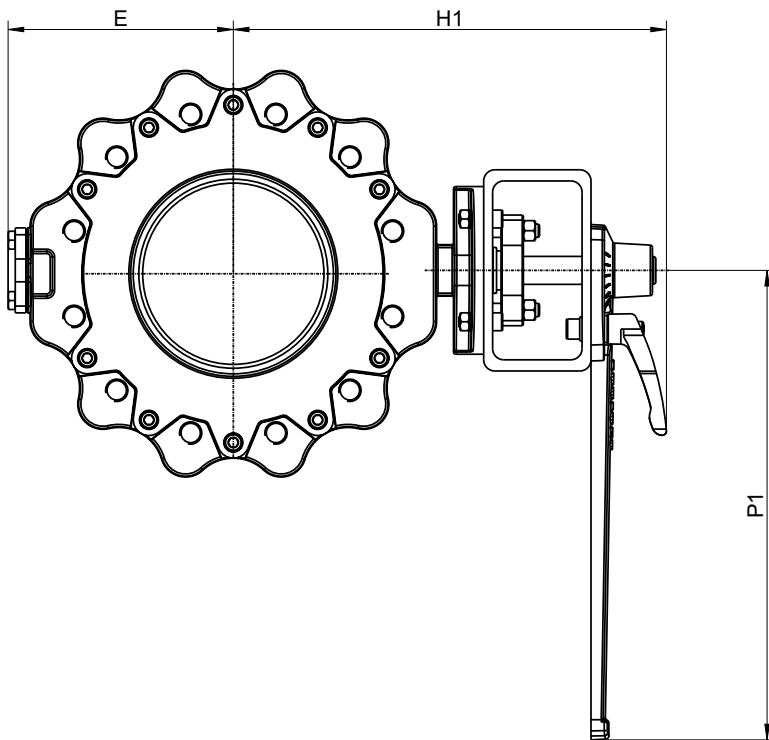

Parts			
Pos.	Sp.p.	Description	Fig. 34./54.123
50	x	Hand lever	
	L Spare parts		

DN	80	100	125	150	200 ¹⁾
----	----	-----	-----	-----	-------------------

Dimensions						
E	(mm)	119	136	155	170	202
H1 (to middle of valve)	(mm)	294	318	332	369	410
P1	(mm)	300	300	300	420	420

Weights with hand lever					
1.0619+QT	Fig. 34.123	short pattern	(kg)	on request	
		middle pattern	(kg)		
1.4408	Fig. 54.123	short pattern	(kg)		
		middle pattern	(kg)		

Hand lever not available for PN40

¹⁾ CS-version is not possible.

ZEDOX® Thread Connection high performance valve with worm gear

Opening and closing of the valves with the handwheel.

The position of the disc can be seen on a position indicator on top of the gear.

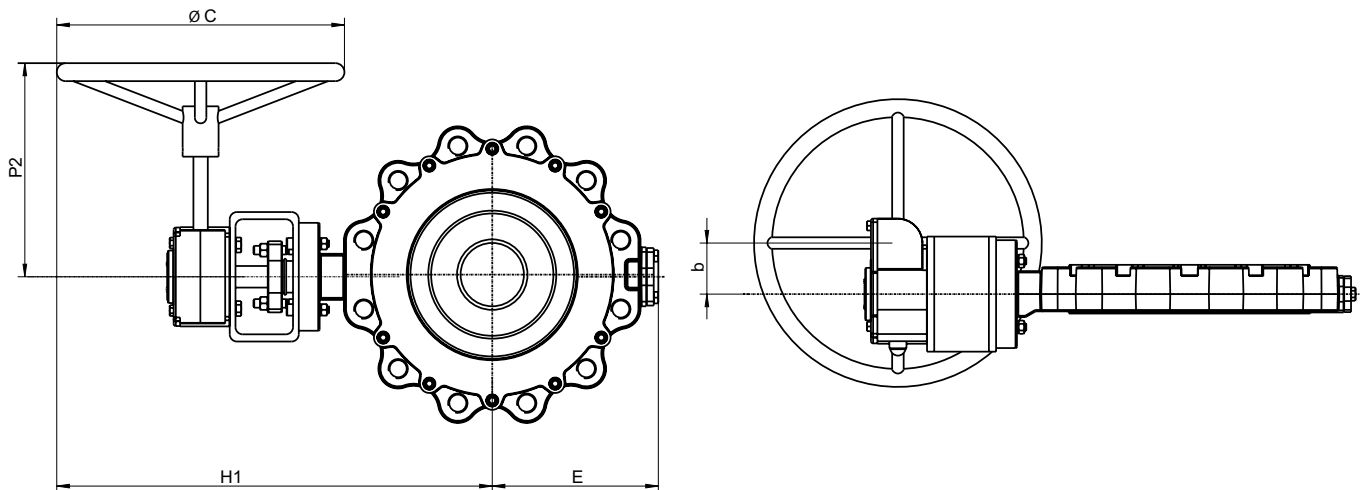

Parts			
Pos.	Sp.p.	Description	Fig. 34./35./54./55.123
500	x	Worm gear	
	L Spare parts		

DN	80	100	125	150	200	250	300	350	400	450	500	600	700	800
----	----	-----	-----	-----	-----	-----	-----	-----	-----	-----	-----	-----	-----	-----

Face-to-face dimension acc. to ISO 5752 / DIN EN 558-1															
L Series 20 (short pattern)	(mm)	46	52	56	56	60	68	78	78	102	114	127	154	165	190
L Series 25 (middle pattern)	(mm)	49	56	64	70	71	76	83	92	-	-	-	-	-	-

Dimensions															
b	(mm)	52	52	52	71	71	71	86	86	130	130	53	182	182	182
ØC	(mm)	200	200	200	200	200	300	400	400	500	500	500	500	500	500
E	(mm)	119	136	155	170	202	231	273	305	333	359	394	460	510	570
H1	(mm)	344	369	380	420	461	556	646	673	781	809	888	985	1107	1155
P2	(mm)	217	217	217	247	247	282	285	285	387	387	382	500	500	545
Type of gear		AB210 -10N	AB210 -10N	AB210 -10N	AB550N	AB550N	AB550N	AB550N	AB880N	AB880N	AB2000N	AB2000N	AB2000N	AB6800N -PR4	AB6800N -PR4

Weights with manual gear Rotork ¹⁾			
1.0619+QT	Fig. 34./35.123	short pattern	(kg)
		middle pattern	(kg)
1.4408	Fig. 54./55.123	short pattern	(kg)
		middle pattern	(kg)

on request

¹⁾ Weight of hand wheel is not included

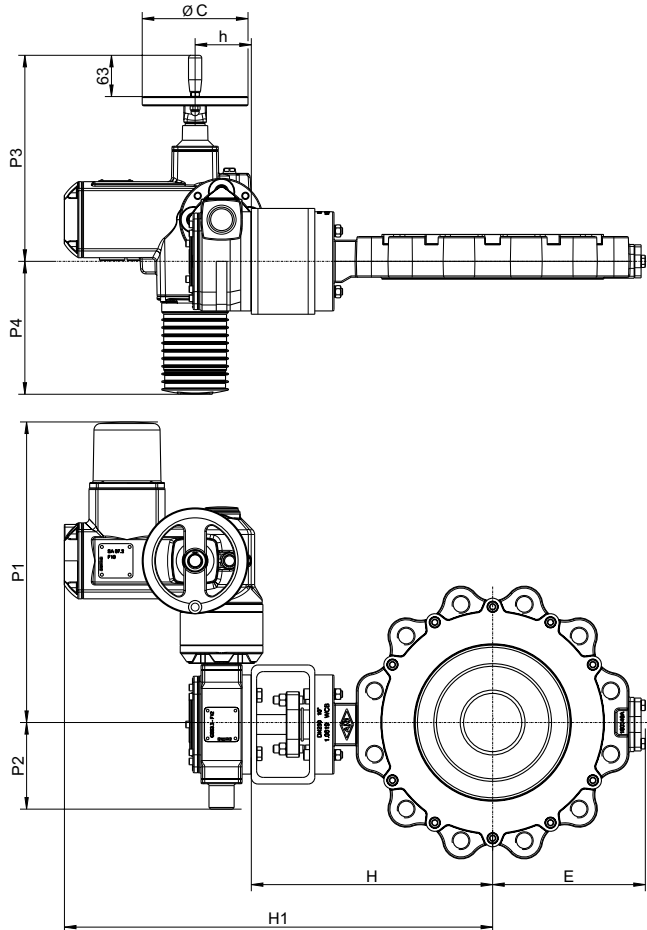
ZEDOX® Thread Connection high performance valve with electric rotary actuator Auma

DN		80	100	125	150	200	250	300	350	400	450	500	600	700	800
Dimensions															
ØC	(mm)	160	160	160	160	160	160	200	200	160	160	160	200	160	160
E	(mm)	119	136	155	170	202	231	273	305	333	359	394	460	510	570
h	(mm)	80	80	80	80	85	85	107	107	115	115	115	125	130	130
H	(mm)	215	240	251	279	320	365	404	431	476	504	574	676	798	846
H1	(mm)	493	518	529	557	603	648	708	736	789	817	887	999	1126	1174
P1	(mm)	393	393	393	393	421	421	428	428	547	547	547	554	698	698
P2	(mm)	98	98	98	98	128	128	133	133	189	189	189	194	290	290
P3	(mm)	302	302	302	302	315	315	334	334	352	352	352	379	412	412
P4	(mm)	214	214	214	214	201	201	202	202	164	164	164	157	175	175
Type of actuator PN25 max. differential pressure 16 bar, for CS- and TS-version		SA07.2- GS50.3 (51:1)- F07	SA07.2- GS50.3 (51:1)- F07	SA07.2- GS50.3 (51:1)- F07	SA07.2- GS50.3 (51:1)- F10	SA07.6- GS63.3 (51:1)- F12	SA07.6- GS63.3 (51:1)- F12	SA10.2- GS80.3 (53:1)- F14	SA10.2- GS80.3 (53:1)- F14	SA07.6- GS100.3 (208:1)- F16	SA07.6- GS100.3 (208:1)- F16	SA07.6- GS100.3 (208:1)- F16	SA10.2- GS125.3 (208:1)- F25	SA07.6- GS160.3 (880:1)- F30	SA07.6- GS160.3 (880:1)- F30
Output drive	1/min	22	22	22	22	22	22	22	22	45	45	45	45	90	90
Operating time	s/90°	35	35	35	35	35	35	36	36	69	69	69	69	147	147
Type of actuator PN40 max. differential pressure 16 bar, only for CS-version		SA07.2- GS50.3 (51:1)- F07	SA07.2- GS50.3 (51:1)- F07	SA07.2- GS50.3 (51:1)- F07	SA07.2- GS50.3 (51:1)- F10	SA07.6- GS63.3 (51:1)- F12									
Output drive	1/min	22	22	22	22	22									
Operating time	s/90°	35	35	35	35	35									

Weights with electric actuator				
1.0619+QT	Fig. 34./35.123	short pattern	(kg)	on request
		middle pattern	(kg)	
1.4408	Fig. 54./55.123	short pattern	(kg)	
		middle pattern	(kg)	

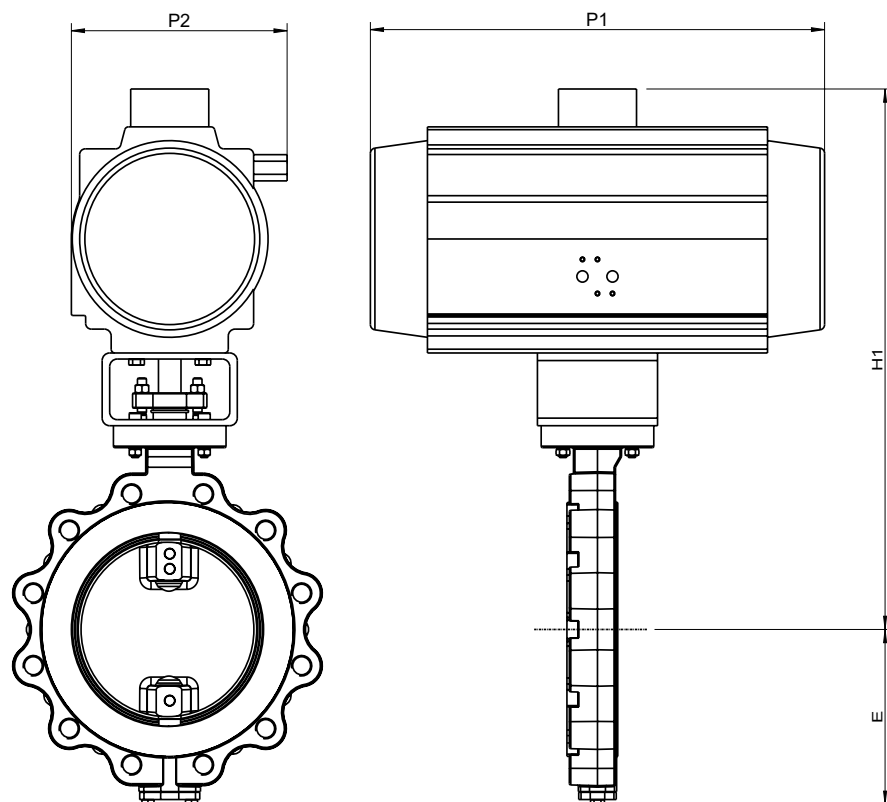
ZEDOX® Thread Connection high performance valve with pneumatic rotary actuator AIR-TORQUE

Type of actuator	P1 (mm)	P2 (mm)
SC00220	304	136
SC00300	333	146,5
SC00450	394,5	166
SC00600	422,5	181
SC00900	474	200
SC01200	528	221,5
SC02000	605	262
SC03000	710	330
SC04000	812	371
SC05000	855	418
SC10000	950	528

Position A



Position B

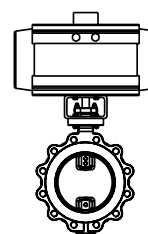

DN	80	100	125	150	200	250	300	350	400	450	500
----	----	-----	-----	-----	-----	-----	-----	-----	-----	-----	-----

Face-to-face dimension acc. to ISO 5752 / DIN EN 558-1												
L Grundreihe 20 (kurze Bauform)	(mm)	46	52	56	56	60	68	78	78	102	114	127
L Grundreihe 25 (mittlere Bauform)	(mm)	49	56	64	70	71	76	83	92	-	-	-

Dimensions												
E	(mm)	119	136	155	170	202	231	273	305	333	359	394
H1 ¹⁾	(mm)	472	517	547	650	715	814	937	991	1224	1252	1322

Type of actuator for max. differential pressure 16 bar ²⁾												
Spring closes flow from disc side actuating pressure actuator 5 bar	TS	SC00220-5/6	SC00450-4	SC00450-5/6	SC00600-5/6	SC01200-5	SC02000-5	SC3000-5	SC4000-5/6	SC10000-4	SC10000-4/5	on request
	CS	SC00300-5/6	SC00450-5	SC00600-5/6	SC00900-5	SC01200-5/6	SC02000-5/6	SC4000-5	SC05000-5/6	SC10000-4	SC10000-5/6	
Spring closes flow from disc side actuating pressure actuator 6 bar	TS	SC00220-5/6	SC00300-6	SC00450-5/6	SC00600-5/6	SC01200-5	SC02000-5	SC3000-5	SC4000-5/6	SC05000-6	SC10000-4/5	on request
	CS	SC00300-5/6	SC00450-5	SC00600-5/6	SC00900-5	SC01200-6	SC02000-6	SC4000-5	SC05000-5/6	SC10000-4	SC10000-5/6	
Spring closes flow from shaft side actuating pressure actuator 5 bar	TS	SC00220-4/5	SC00300-5	SC00450-4/5	SC00600-4/5	SC00900-5/6	SC02000-4	SC03000-4	SC04000-4/5	SC05000-5	SC10000-4	SC10000-5/6
	CS	SC00220-5/6	SC00450-4	SC00450-5/6	SC00600-5/6	SC001200-5	SC02000-5	SC03000-5/6	SC04000-5/6	SC10000-4	SC10000-4/5	on request
Spring closes flow from shaft side actuating pressure actuator 6 bar	TS	SC00220-4/5	SC00300-5	SC00450-4/5	SC00450-6	SC00900-5/6	SC02000-4	SC02000-6	SC04000-4/5	SC05000-5	SC10000-4	SC10000-5/6
	CS	SC00220-5/6	SC00450-4	SC00450-5/6	SC00600-5/6	SC001200-5	SC02000-5	SC03000-5/6	SC04000-5/6	SC05000-6	SC10000-4/5	on request

Weights with pneumatic actuator ¹⁾			
1.0619+QT	Fig. 34./35.123	short pattern	(kg)
		middle pattern	(kg)
1.4408	Fig. 54./55.123	short pattern	(kg)
		middle pattern	(kg)

on request

For steam duty use the next actuator up

¹⁾ with largest actuator option

²⁾ other differential pressures on request

Actuator bigger than DN500 on request

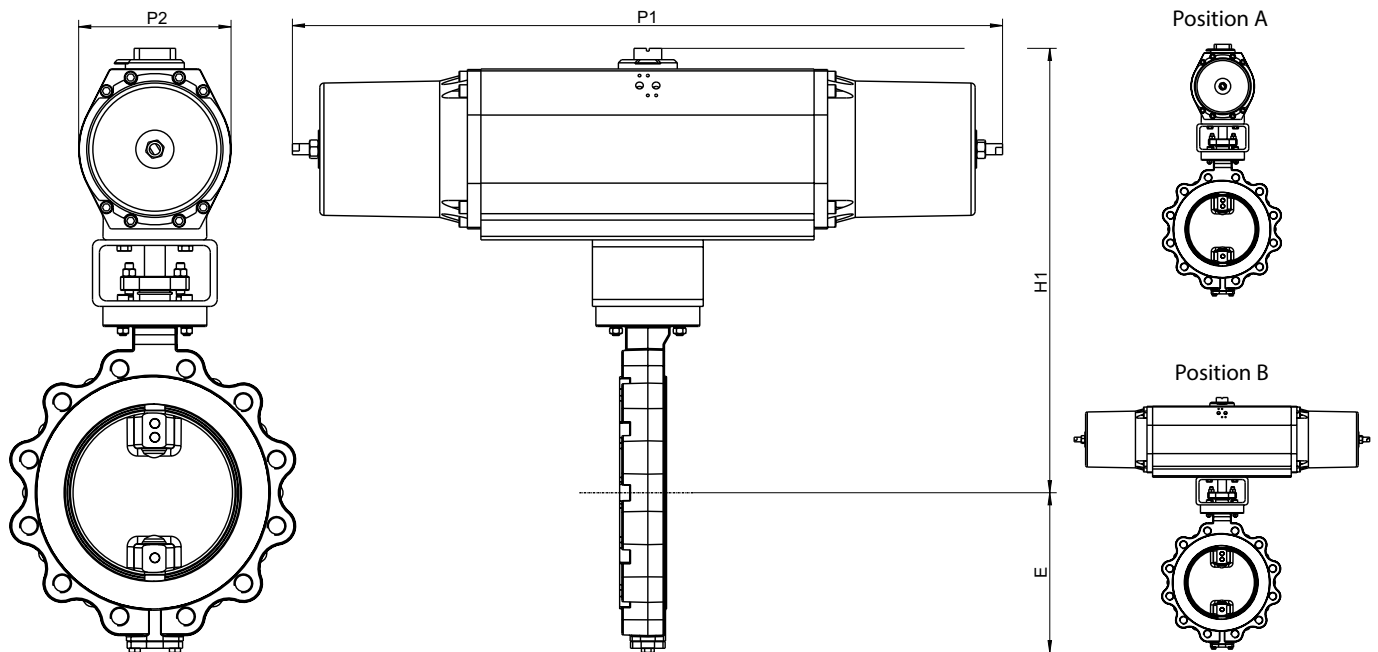
ZEDOX® Thread Connection high performance valve with pneumatic actuator Rotork RC

DN	80	80 (PN40)	100	125	150	200	250	300	350	400 ²⁾	450 ²⁾	500 ²⁾	
Dimensions													
E	(mm)	119	136	136	155	170	202	231	273	305	333	359	394
H1	(mm)	460	460	485	496	554	708	743	997	1071	1141	1134	1204
P1	(mm)	375	570	570	570	570	655	1020	1020	1020	1020	1700	1700
P2	(mm)	144	144	144	144	144	220	220	220	220	220	380	380
Type of actuator spring closes ¹⁾		RC250-SR	RC260-SR	RC260-SR	RC260-SR	RC260-SR	RC270-SR	RC280-SR	RC88-SR	RC88-SR	RC88-SR	RCG100	RCG100
Type of actuator double acting ¹⁾		RC230-DA	RC230-DA	RC240-DA	RC240-DA	RC250-DA	RC260-DA	RC260-DA	RC270-DA	RC280-DA	RC280-DA	RC280-DA	RC-88-DA

Weights with pneumatic actuator				
1.0619+QT	Fig. 34./35.123	short pattern	(kg)	on request
		middle pattern	(kg)	
1.4408	Fig. 54./55.123	short pattern	(kg)	
		middle pattern	(kg)	

¹⁾ At air pressure 6 bar

²⁾ Δ P max = 16 bar

Actuator bigger than DN500 on request

Actuator flange connection, with 2 parallel keys 180° rotated

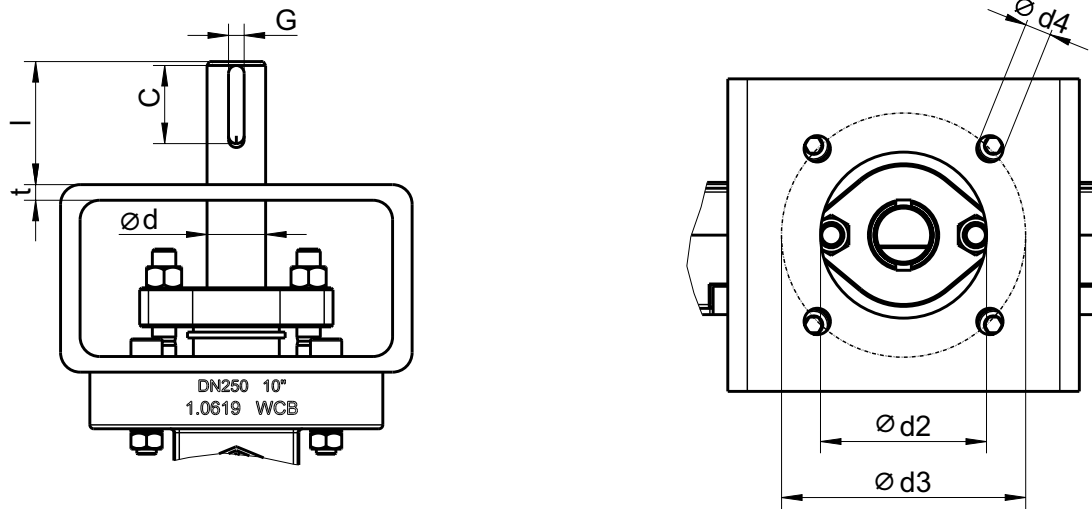

DN		80	100	125	150	200	250	300	350	400	450	500	600	700	800
Connection EN ISO 5211		F07			F10	F12		F14		F16			F25	F30	
$\varnothing d$ (stem diameter)	(mm)	15	20	20	25	25	30	35	40	50	50	60	70	70	90
$\varnothing d2$ (inside diameter)	(mm)	55			70	85		100		130			200	230	
$\varnothing d3$ (screw-hole circle diameter)	(mm)	70			102	125		140		165			254	298	
n x $\varnothing d4$ (Number x hole- \varnothing)	(mm)	4x9			4x11	4x14		4x18		4x22			8x18	8x22	
C (parallel key length)	(mm)	27	34	34	38	38	42	47	52	62	62	82	92	92	127
G (parallel key width)	(mm)	5	6	6	8	8	8	10	12	14	14	18	20	20	25
l (bare stem length)	(mm)	45	52	52	58	58	63	69	75	86	83	103	119	119	125
t (mounting bracket wall thickness)	(mm)	24	24	24	27	12	15	15	20	17	38	48	48	52	55

Kvs-value / Zeta-value															
DN		80	100	125	150	200	250	300	350	400	450	500	600	700	800
Kvs-value	(m ³ /h)	187	291	609	888	1944	3498	4900	7200	11000	16000	18500	25500	30000	37500
Zeta-value	--	1,87	1,89	1,05	1,03	0,68	0,51	0,54	0,46	0,34	0,26	0,29	0,32	0,43	0,47

Difference between disc outside-diameter and face-to-face															
DN		80	100	125	150	200	250	300	350	400	450	500	600	700	800
B	(mm)	20	27	38	50	73	97	110	138	150	172	192	219	260	300
D	(mm)	66	83	108	134	185	236	280	333	378	429	475	567	665	759

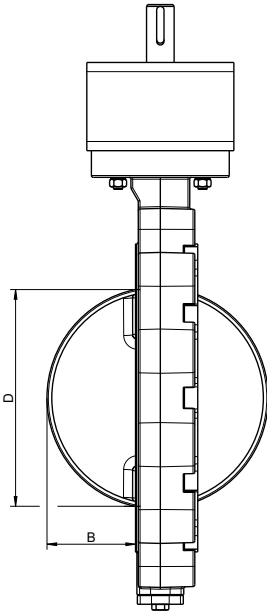

myValve® - Your Valve Sizing-Program.

myValve® is a powerful software tool that not only helps you size your system components; it also gives you instant access to all other data about the selected product, such as order information, spare parts drawings, operating instructions, data sheets, etc., whenever you need it.

Contents:
Module ARI-high performance valve ZEDOX-calculation

- Sizing of flow quantity Kv, volume flow Q, pressure drop p, sound level; Selecting the valve size with given capacity; Selection of the actuator.
- Calculation of torque for actuators in flow from shaft side and flow from disc side.

Media:
Integrated media-data bank (more than 160 media) with conditions:

- Vapours / gases
- Steam (saturated and superheated)
- Liquids

Special features:

- Project administration of the calculation and product data incl. spare part drawings concerning to project and tag number.
- Direct output or calculation and product data in PDF format.
- Product data could be taken for a direct order.
- SI- and ANSI-units with direct conversion to another data bank.
- Settings with over pressure or absolute pressure.
- All ARI valves are integrated in a data bank.
- Direct access concerning to the product on data sheets, operating instructions, pressure-temperature-diagram and spare part drawings
- Operation in company networks possible (no complex installations on individually PC's necessary).
- Extensive catalogue extending over several product groups.

System Requirements:

Windows operating systems, Linux, etc.