

## PEKOS STAINLESS STEEL FULL-BORE

## FLANGED ANSI 150 BALL VALVE

## Key features

- 2-piece stainless steel body
- Full-bore
- Lever operated (gearbox version on request)
- Flanged ANSI 150 connections
- Sizes available: 1/2" to 6" (larger sizes on request)
- Pressure rated: Class 150
- Temperature rated: -29°C to 180°C
- ATEX approved



## DETAILS

The Pekos Fig Z 16 TTTGV ANSI 150 stainless steel full-bore ball valve is an ATEX certified ball valve suitable for a wide range of industries.

Manufactured in accordance with many standards including: API 598, API 6D, BS 6755-1, API 6D, B16.34, ANSI B16.5, ANSI B16.10, ISO 5211 and NACE MR0175.

The valve carries a wide range of approvals including: Fire Safe, TA-Luft, ATEX 94-9EC, API 6D, PED 97/23/CE, SIL 3 Capable and EN161/EN264.

3.1 Material Certification included as standard

The valve is a split body design and easily maintained, full spares kits are available.

This valve is offered with PTFE seats as standard, however, a wide range of alternative seats materials are available for different applications (cryogenic, elevated temperatures etc).

If alternative seats/seals are required, please get in touch.

Call 01822 855600 to discuss your project or application further with a member of our technical team or contact us via our online form.

## PEKOS STAINLESS STEEL FULL-BORE

## FLANGED ANSI 150 BALL VALVE

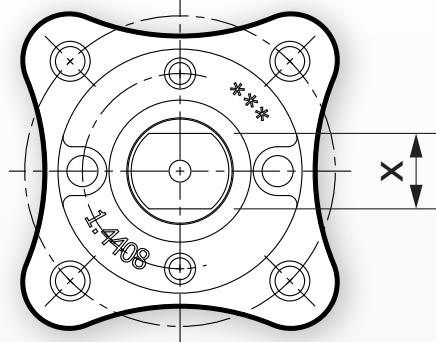

TOP PLATE DETAIL

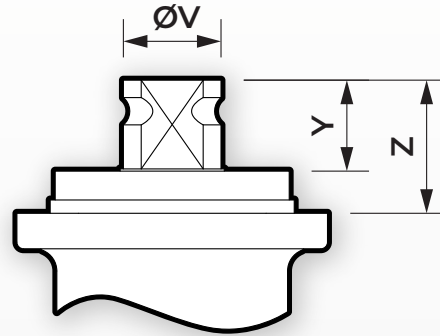

STEM DETAIL

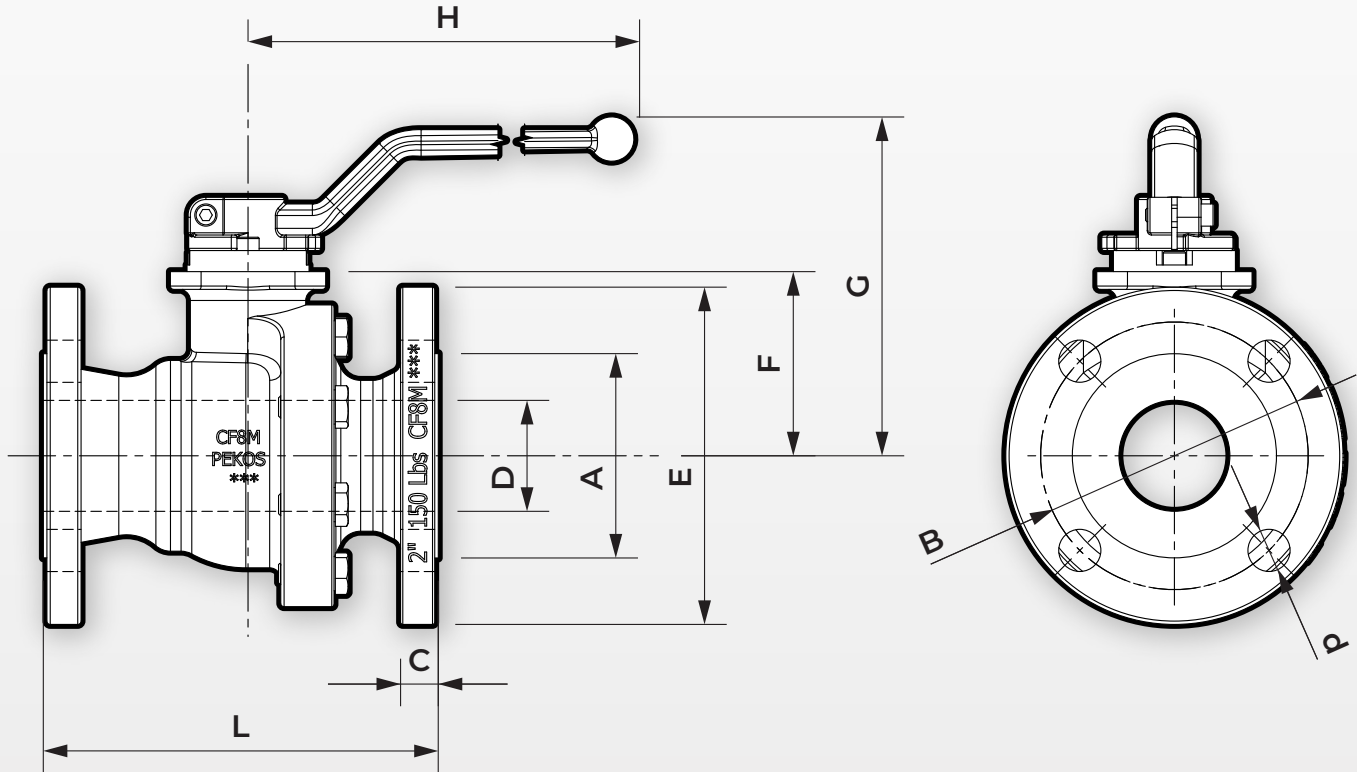

TABLE 1: DIMENSIONS IN MM & TECHNICAL INFORMATION

DN	CL	D	L	E	A	B	C	F	H	G	V	X	Y	Z	n x d	ISO 5211	Torque	MAST	Weight
1/2"	150	15	108	90	35	60	11	45	185	106	14	11	11	13.5	4 x 16	F05	9 Nm	43.5 Nm	2.5 kg
3/4"	150	20	117	100	43	70	12	47	185	108	14	11	11	13.5	4 x 16	F05	11 Nm	43.5 Nm	3.2 kg
1"	150	25	127	110	51	79	14	52	185	113	18	14	17	19.5	4 x 16	F05	16 Nm	80.1 Nm	4.2 kg
1-1/2"	150	40	165	125	73	98	16	75	293	145	22	17	20	30.0	4 x 16	F07	32 Nm	250.4 Nm	7.4 kg
2"	150	50	178	150	92	121	17	83	293	153	22	17	20	30.0	4 x 19	F07	48 Nm	250.4 Nm	10.4 kg
2-1/2"	150	65	190	180	105	140	19	96	293	166	22	17	20	30.0	4 x 19	F07	62 Nm	250.4 Nm	17.0 kg
3"	150	80	203	190	127	152	21	113	350	199	28	22	22	40.0	4 x 19	F10	103 Nm	522.5 Nm	22.5 kg
4"	150	100	229	230	157	191	25	128	350	221	28	22	22	40.0	8 x 19	F10	145 Nm	522.5 Nm	31.6 kg
6"	150	150	394	280	216	241	27	176	740	285	36	27	35	50.0	8 x 22	F12	400 Nm	1073.4 Nm	81.1 kg

Other sizes are available on request.

## PEKOS STAINLESS STEEL FULL-BORE

## FLANGED ANSI 150 BALL VALVE

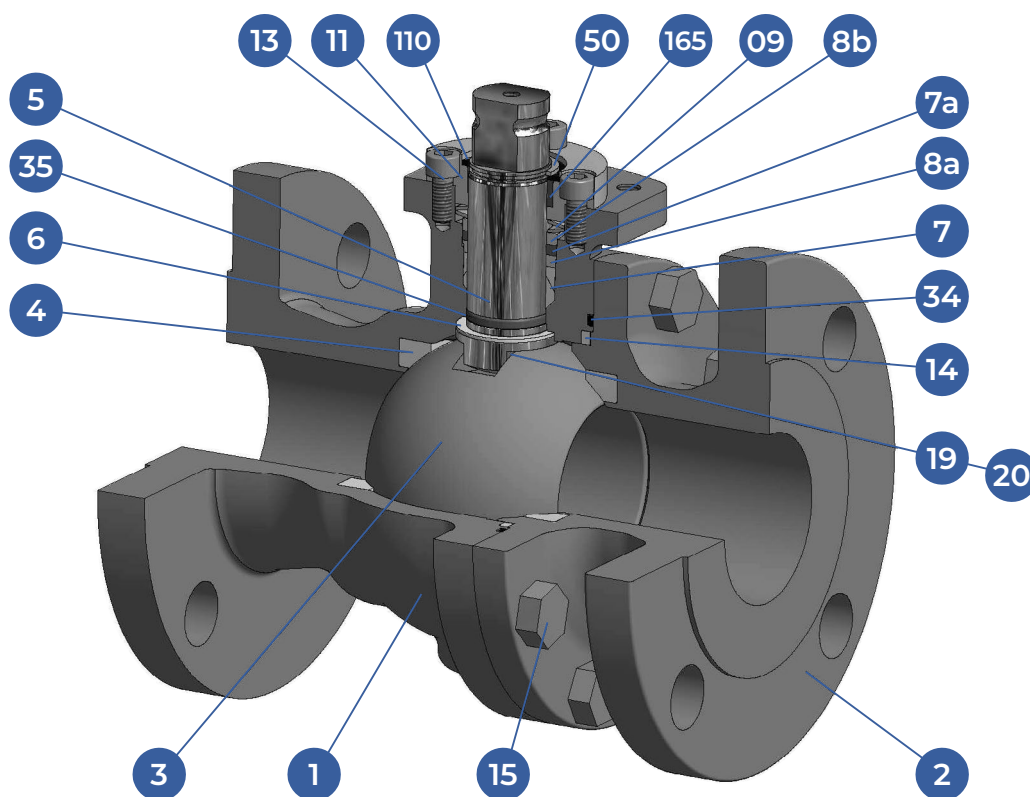

**TABLE 2: MATERIALS**

Part	Description	Material
01	Body 1	S.S. A351 CF8M
02	Body 2	S.S. A351 CF8M
03	Ball	S.S. A351 CF8M
04	Seat	PTFE
05	Stem	S.S. AISI 316
06	Stem seal	PTFE+FG
07	Stem packing 1	PTFE
07a	Stem packing 2	Graphite
08a	Gland packing	S.S. AISI 316
08b	Gland packing 1	S.S. AISI 316
09	Spring washer	S.S. AISI 301
11	Cover	S.S. A351 CF8M
13	Cover bolt	S.S. (316)
14	Body seal 1	PTFE
15	Body bolt	A193 B8M
16	Handle	WCB
17	Handle bolt	1.045(8.8)
19	Spring	S.S. AISI 316
20	Antistatic ball	S.S. AISI 316
34	Body seal 2	Graphite
35	O-ring stem	FKM
50	Subjection ring	S.S. AISI 420
110	Subjection ring seal	S.S. AISI 316 Nitrided
165	Stem bearing	PTFE+FG

## PEKOS STAINLESS STEEL FULL-BORE

## FLANGED ANSI 150 BALL VALVE

### CHART 1: PRESSURE/TEMPERATURE

Pressure (bars)

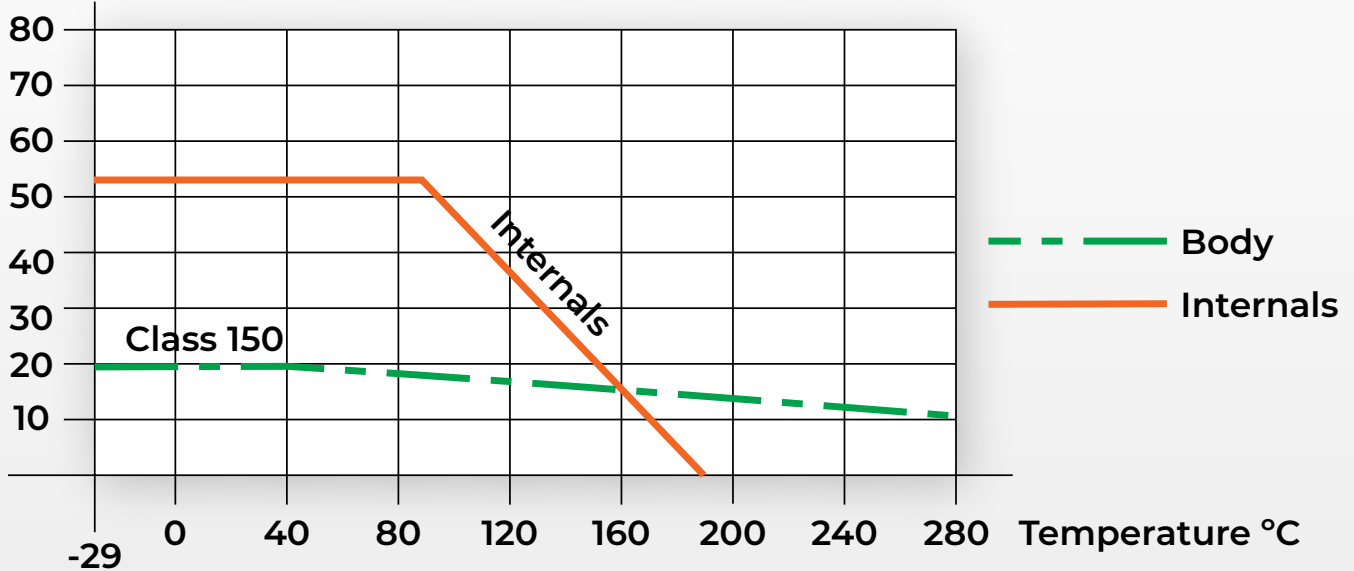

#### TABLE 3: APPROVALS

Approval
Fire Safe
TA-LUFT
ATEX 94-9EC
API 6D
PED 97/23/CE
SIL 3 Capable
EN 161/EN 264

#### TABLE 4 : STANDARDS

Standard
Top Flange: ISO 5211
Flanges: ANSI B16.5
Face to Face: ANSI B16.10
Testing: API 598, API 6D, BS 6755-1
Design: API 6D, B16.34
Materials according to NACE MR0175

#### TABLE 5: PART NUMBERS

Size	DN	SKU
1/2"	DN15	BV5716-100369
3/4"	DN20	BV5716-100370
1"	DN25	BV5716-100371
1-1/2"	DN40	BV5716-100372
2"	DN50	BV5716-100373
2-1/2"	DN65	BV5716-100374
3"	DN80	BV5716-100375
4"	DN100	BV5716-100376
6"	DN150	BV5716-100377