



I Application

Butterfly valves A480, whether manually or automatically operated, can be used in most liquid product applications in the food-processing, pharmaceutical and chemical industries. The design of the butterfly valve between flanges A490 facilitates its installation and maintenance, allowing the extraction of the valve by means of 4 screws while the flanges welded to the installation remain fixed.

The butterfly valve can be operated automatically through an actuator or manually with a handle. The handle blocks the valve in the "open" or "closed" position, although there are also other models with intermediate positions. The actuator transforms the axial movement of the piston into a 90° rotary movement which it transmits to the disc.

I Design and features

Hygienic design according to EHEDG guidelines.

Easily interchangeable manual handles and pneumatic or electric actuators.

Low pressure losses.

Body halves interchangeable with any connection type.

Traceability of components.

Gaskets comply with USP CLASS VI requirements.

I Technical specifications

Materials:

Disc	1.4404 (AISI 316L)
Body halves	1.4301 (AISI 304) or 1.4404 (AISI 316L)
Other St. St. parts	1.4301 (AISI 304)
Gasket	EPDM, HNBR, VMQ or FPM

Surface finish:

Internal	$Ra \leq 0,8 \mu m$
External	Machined

Available sizes:

DIN EN 10357 series A	DN 25 - DN 100
(previously DIN 11850 series 2)	

ASTM A269/270	OD 1" - OD 4"
(corresponds to OD pipe)	

Connections	Weld, male, nuts, clamp
-------------	-------------------------



I Technical specifications

Operating limits:

Working temperature (EPDM)	-10 °C to +120 °C	14 °F to 248 °F
Temperature SIP, max. 30 min.	+140 °C	284 °F
Minimum working pressure (absolute P.)	20 kPa (0,2 bar)	3 PSI
Maximum working pressure	1000 kPa (10 bar) ⁽¹⁾	145 PSI ⁽¹⁾

*Note (1): Classified according to Directive 97/23/CE as Category I valves for use with fluids of Group 1.

DN	25	32	40	50	65	80	100
Dry torque* [Nm]	5	5	5	8	15	25	30

OD	1"	1½"	2"	2½"	3"	4"
Dry torque* [Nm]	5	5	8	15	25	30

*For rotating the valve disc in a dry seal ring.

I Technical specifications: handles and actuators

Handles:

Multiposition handle	1.4301 (AISI 304) + plastic (PA6) or 1.4301 (AISI 304)
Two position handle	1.4301 (AISI 304) + plastic (PF31)

Actuators:

Housing	1.4307 (AISI 304L)
Support	1.4301 (AISI 304)
Air pressure	6-8 bar
Air connection	G 1/8 (Ø6 pipe)

Air consumption

Actuator	Single-acting	Double-acting
A940 - T1	1,3	3,4
A940 - T2	2,1	4,9

Compressed air consumption at P_{rel}=6 bar (litres N/cycle)

Standard assembly

Valve	A940 - T1	A940 - T2
A480 & A490	DN 10 to 50 OD 1" to 2"	DN 65 to 100 OD 2½" to 4"

I Options

Different handle types.

Single- or double-acting actuator or electric actuator.

Inductive position sensors.

C-TOP S control unit.

ATEX version available.



I Dimensions

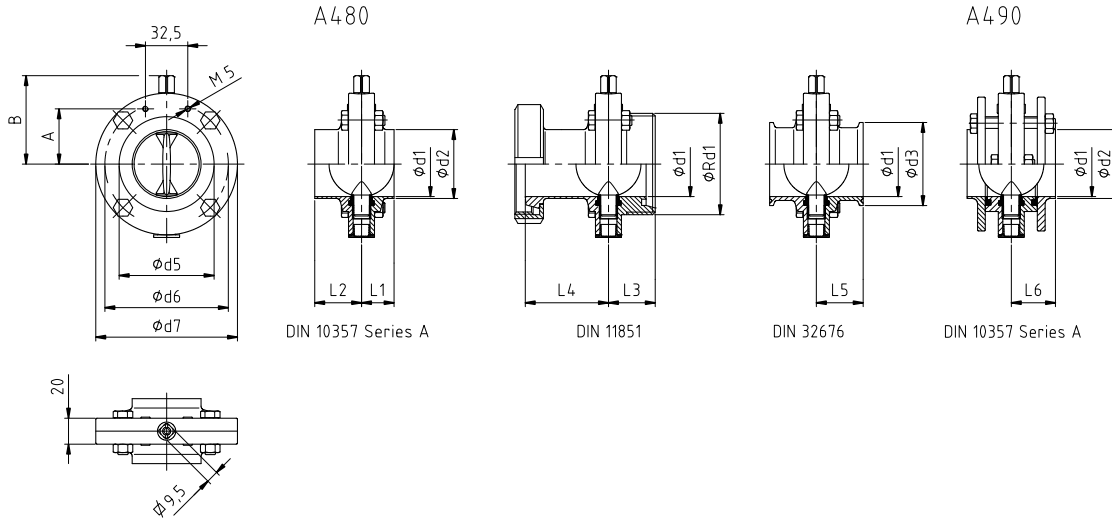

10.010.32.0045

DN	Valve				Connection								Weight (kg)				
	Ød5	Ød6	Ød7	A	B	Ød1	Ød2	ØRd1	Ød3	L1	L2	L3	L4	L5	L6	A480*	A490
25	47	69	83	29,5	55,0	26	29	Rd 52 x 1/6"	50,5	25	32	32	47	32	34	0,9	1,5
32	53	75	89	32,5	58,0	32	35	Rd 58 x 1/6"	50,5	25	32	32	50	32	34	1,0	1,6
40	60	82	96	36,0	61,5	38	41	Rd 65 x 1/6"	50,5	25	36	36	51	36	34	1,2	1,8
50	73	95	109	42,5	68,0	50	53	Rd 78 x 1/6"	64,0	25	36	36	53	36	34	1,4	2,2
65	90	112	126	51,0	76,5	66	70	Rd 95 x 1/6"	91,0	25	38	38	57	38	34	1,8	2,8
80	105	127	141	58,5	84,0	81	85	Rd 110 x 1/4"	106	30	45	45	67	45	36	2,3	3,7
100	125	147	161	68,5	94,0	100	104	Rd 130 x 1/4"	119	30	45	45	74	45	36	2,9	4,6

*Weld connection



The information is for guidance only. We reserve the right to modify any material or feature without notice in advance. Photos are not binding. For further information, please, consult our web site.

I Dimensions

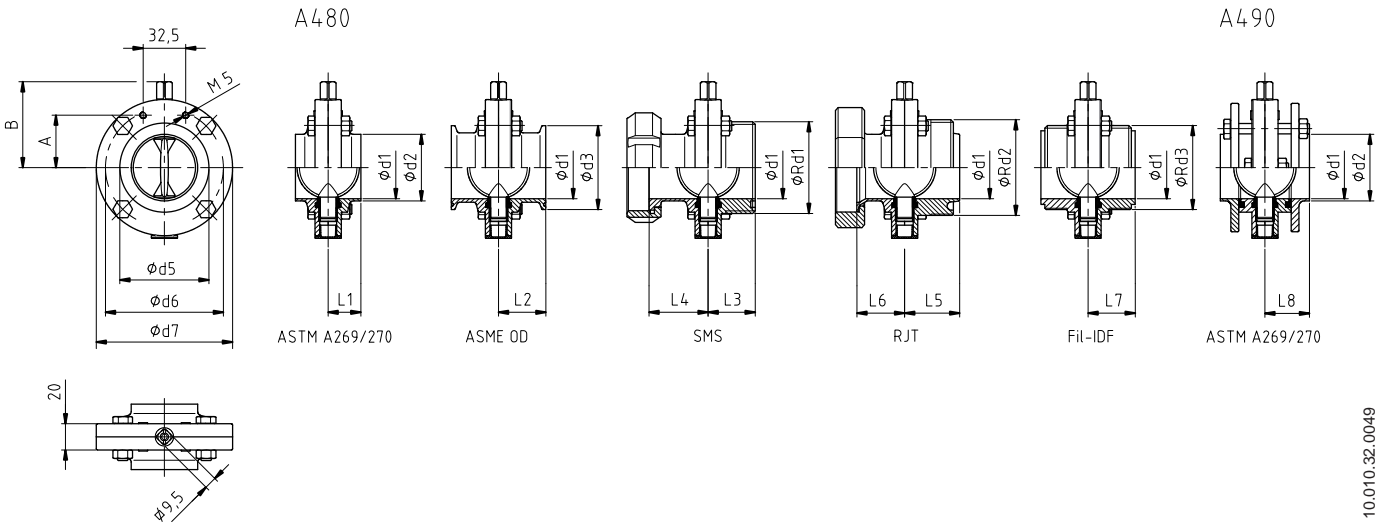

10.010.32.0049

OD	Valve						Connection						Weight (kg)					
	Ød5	Ød6	Ød7	A	B	Ød1	Ød2	Ød3	ØRd2	ØRd3	L1	L2	L5	L6	L7	L8	A480*	A490
1"	42	64	78	27,0	52,5	22,1	25,4	50,5	Rd 45,72 x 1/8"	Rd 37,13 x 1/8"	25	32	39	45	39	34	0,8	1,3
1½"	55	77	91	33,5	59,0	34,8	38,1	50,5	Rd 58,42 x 1/8"	Rd 50,65 x 1/8"	25	36	42	49	36	34	1,0	1,7
2"	68	90	104	40,0	65,5	47,5	50,8	64,0	Rd 72,72 x 1/6"	Rd 64,16 x 1/8"	25	36	42	53	36	34	1,3	2,0
2½"	80	102	116	46,0	71,5	60,2	63,5	77,5	Rd 85,42 x 1/6"	Rd 77,56 x 1/8"	25	38	42	57	38	34	1,5	2,4
3"	93	115	129	52,5	78,0	72,9	76,2	91,0	Rd 98,12 x 1/6"	Rd 91,19 x 1/8"	25	38	42	57	38	36	1,8	3,0
4"	125	147	161	68,5	94,0	97,4	101,6	119	Rd 123,52 x 1/6"	Rd 125,9 x 1/6"	30	45	45	64	45	36	2,9	4,8

*Weld connection

SMS	Connection			Weight (kg)
	ØRd1	L3	L4	A480*
25	Rd 40 x 1/6"	32	40	1,0
38	Rd 60 x 1/6"	36	45	1,6
51	Rd 70 x 1/6"	36	45	1,9
63,5	Rd 85 x 1/6"	38	49	2,5
76	Rd 98 x 1/6"	38	49	2,9
101,6	Rd 132 x 1/6"	45	60	5,7
104	Rd 125 x 1/4"	45	60	4,6

*Male connection



FT.A480_A490.1.EN_0920

I Dimensions

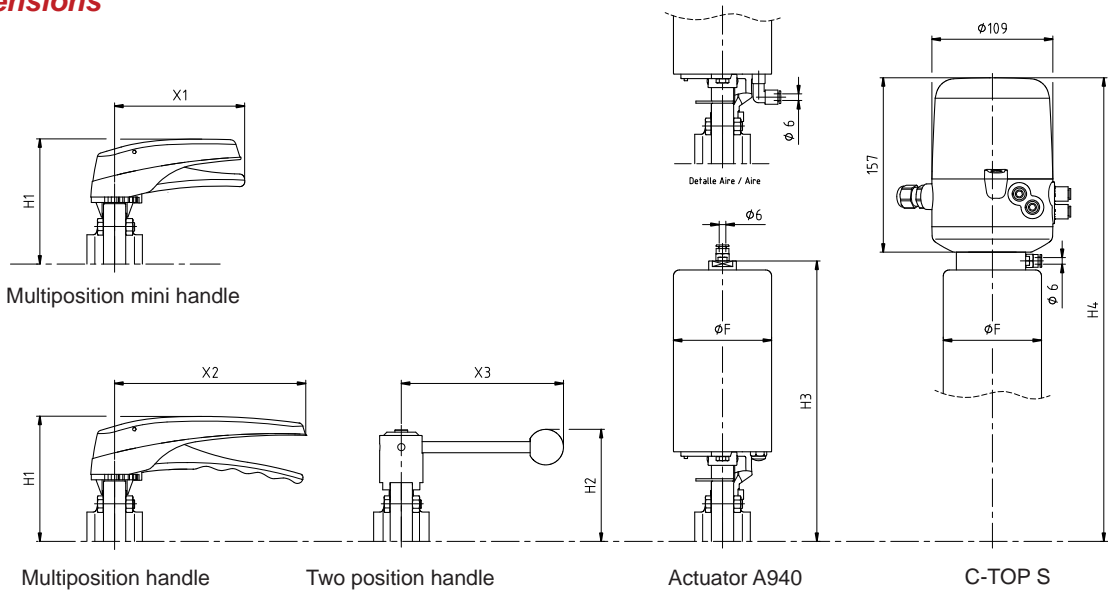

10.010.32.0051

Handles and actuators									
DN	H1	X1	X2	H2	X3	T1 (ØF = 76)		T2 (ØF = 88,5)	
						H3	H4	H3	H4
25	100	118	173*	88	146	218	383	240*	405*
32	104	118	173*	92	146	221	386	243*	408*
40	107	118*	173	95	146	225	390	247*	412*
50	113	118*	173	101	146	231	396	253*	418*
65	122	118*	173	110	146	-	-	262	427
80	130	118*	173	117	175	-	-	269	434
100	140	118*	173	128	175	-	-	279	444

Handles and actuators									
OD	H1	X1	X2	H2	X3	T1 (ØF = 76)		T2 (ØF = 88,5)	
						H3	H4	H3	H4
1"	98	118	173*	86	146	216	381	238*	403*
1½"	104	118*	173	92	146	222	387	244*	409*
2"	110	118*	173	98	146	229	394	251*	416*
2½"	117	118*	173	104	146	-	-	257	422
3"	123	118*	173	111	146	-	-	263	428
4"	140	118*	173	128	175	-	-	279	444

*Not standard or not recommended



I Sizing

The following formula can calculate the required Kv for products with a similar density and viscosity to water:

$$K_v = \frac{Q}{\sqrt{\Delta p}}$$

where:

Q = flow (m³/h)

Δp = drop in pressure in the valve (bar)

Note: Tests performed with water at 20°C.

